

BENZI

PARTNER DES FACHHANDELS UND



DER WERKSTÄTTEN SEIT 1904

IDENTIFIKATIONSHILFEN & SERVICES

BENZI 

 **ENERGY**

 **evolution**
HIGH PERFORMANCE SERIES

Schaffelhuber
Großhandel · Ersatzteile & Zubehör für Landmaschinen und Industriebedarf seit 1904





Nummernaufbau BENZI

BL	01	101	AA	C10	010
1	2	3	4	5	6
Serie BL	Größe / Size 01	Länge Kreuzmitte - Kreuzmitte	Schutz-Typ	Anschluss schlepperseitig	Anschluss maschinenseitig
1	BL = Serie BL				
2	01 = Größe/Size 01				
3	101 = Länge Kreuzmitte - Kreuzmitte in mm				
4	AA = Typ Schutz				
5	C10 = Anschluss schlepperseitig				
6	010 = Anschluss maschinenseitig				



Serie Energy: Standard-Ausführung
 Serie Evolution: Profi-Ausführung mit erhöhten Schmierintervallen
 Energy 10 - 200 PS, Evolution 60 - 300 PS

Sämtliche Artikel finden Sie in unserem Webshop

www.schaffelhuber.de

Bei Fragen zu Benzi helfen Ihnen unsere Fachexperten sehr gerne weiter.

Service-Hotline: +49 (0) 8142 66 99 1-50
 J.R.H. Schaffelhuber GmbH & Co. KG
 Gadastraße 14, 85232 Bergkirchen bei München

BENZI ENERGY



BENZI EVOLUTION











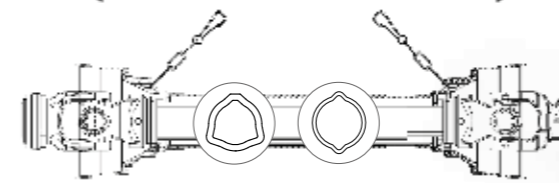



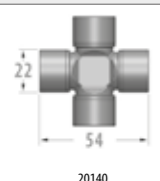







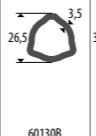
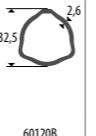





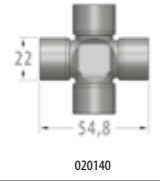







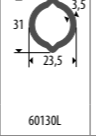
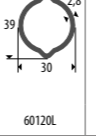





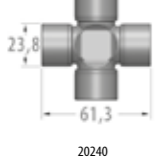



Made in Italy

Albero tipo Shaft size Arbre type Gelenk.Type	540 * giri/min rpm U / min			1.000 * giri/min rpm U / min		
	kW	CV-HP	Mn (Nm)	kW	CV-HP	Mn (Nm)
L 01	12	16	210	18	24	175
L 23	20	27	355	31	42	295
L 04	28	38	500	44	60	415
L/T05	39	53	695	61	83	580
L/T67	66	90	1.175	102	139	975
L/T 09	92	125	1.625	142	193	1.360

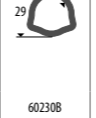
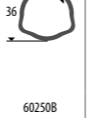









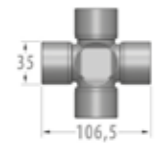



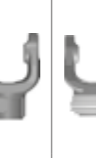







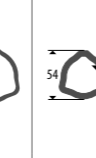
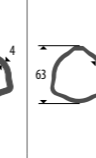





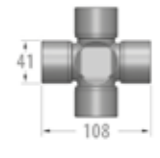



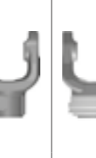
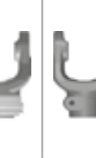







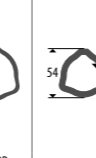
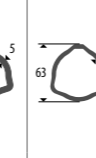





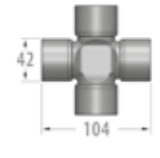





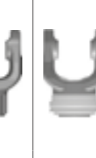





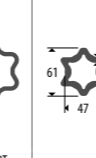
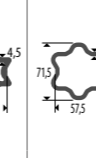





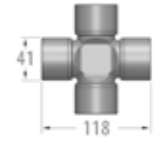





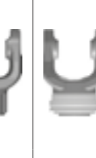

Albero tipo Shaft size Arbre type Gelenk.Type	540 * giri/min rpm U / min			1.000 * giri/min rpm U / min		
	kW	CV-HP	Mn (Nm)	kW	CV-HP	Mn (Nm)
B 01	12	16	210	18	25	172
B 02	15	21	270	23	31	220
B 03	22	30	390	35	47	330
B 04	26	35	460	40	55	380
B 05	35	47	620	54	74	520
B 06	47	64	830	74	100	710
B 07	55	75	970	87	118	830
B 08	70	95	1.240	110	150	1.050
B 09	88	120	1.560	140	190	1.340
B 10	106	145	1.890	170	230	1.630

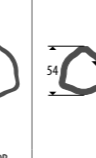
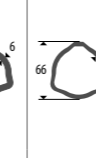

Lunghezza L (mm) - Length L (mm) Longueur L (mm) - Length L (mm)	610	660	710	760	810	860	910	1010	1110	1210	1310
Codice - Part No. Réf. - Best. Nr.	061	066	071	076	081	086	091	101	111	121	131

Albero tipo Shafts size Arbre type Gelenk. Typ	Crociera U. joints Croisillons Kreuzgarnituren	Forcella d'attacco End yokes Machoire d'extrémité Anschlussgabeln				Forcelle int. / est. Inner / outer yokes Machoire int. / ext. Inn. / auss. gabeln	Giunti Joints Joints Kupplungen	Profili telescopici Telescopic profiles Profils coulissants Profilrohre	Ghiere Retainers Bagues Gleitring	Protezioni Shields Protecteurs Schutze	Limitatore di coppia - Torque limiters - Limiteurs de couple - Kupplungen						
		1.3/8"-6	1.3/8"-21	1.3/4"-6	1.3/4"-20						Bullone trancio Shear bolt clutch Limiteur à boulon Scherbolzenkupplung	Frizione a dischi Friction clutch Friction à disques Reibkupplung	Limitatore a nottolini Radial pin clutch Limiteur à cames Sternratsche	Limitatore automatico Cam clutch/cut out clutch Limiteur débrayable Nockenschaltkupplung	Ruota libera Overrunning clutch Roue libre Freilauf		
B01	 20140	 10110	 101C10	 10112	 101C12	 50130B	 50120B	 70130B 701C30B	 70120B 701C20B	 60130B	 60120B	 G0130	 G0150	 P1	 NZL0138060	 RZL0138RD	
L01	 020140	 010110	 0101C10	 010112	 0101C12	 50130L	 50120L	 70130L 701C30L	 70120L 701C20L	 60130L	 60120L	 G0150	 G0150	 P1	 NZL0138060	 RZL0138RD	
B02	 20240	 10210	 102C10	 10212	 102C12	 50230B	 50220B	 70230B 702C30B	 70220B 702C20B	 60230B	 60250B	 G0150	 G0220	 P1	 BTB02384806A	 NZL0238060	 RZL0238RD

Albero tipo Shafts size Arbre type Gelenk. Typ	Crociere U. joints Croisillons Kreuzgarnituren	Forcella d'attacco End yokes Machoire d'extrémité Anschlussgabeln				Forcelle int. / est. Inner /outer yokes Machoire int. / ext. Inn./ auss. gabeln	Giunti Joints Joints Kupplungen	Profili telescopici Telescopic profiles Profils coulissants Profilrohre	Ghiere Retainers Bagues Gleitring	Protezioni Shields Protecteurs Schutze	Limitatore di coppia - Torque limiters - Limiteurs de couple - Kupplungen													
		1.3/8"-6	1.3/8"-21	1.3/4"-6	1.3/4"-20						Bullone trancio Shear bolt clutch Limiteur à boulon Scherbolzenkupplung	Frizione a dischi Friction clutch Friction à disques Reibkupplung	Limitatore a nottolini Radial pin clutch Limiteur à cames Sternratsche	Limitatore automatico Cam clutch/cut out clutch Limiteur débrayable Nockenschaltkupplung	Ruota libera Overrunning clutch Roue libre Freilauf									
L23	 020240																							
B03	 20340																							
B04	 20440																							
L04	 020440																							
B05	 20540																							
L/T05	 020540																							
B06	 20640																							
B07	 20740																							
L/T67	 026740																							

Albero tipo Shafts size Arbre type Gelenk. Typ	Crociere U. joints Croisillons Kreuzgarnituren	Forcella d'attacco End yokes Machoire d'extrémité Anschlussgabeln								Forcelle int. / est. Inner /outer yokes Machoire int. / ext. Inn./ auss. gabeln	Giunti Joints Joints Kupplungen	Profili telescopici Telescopic profiles Profils coulissants Profilhöhre	Ghiere Retainers Bagues Gleitring	Protezioni Shields Protecteurs Schutze	Limitatore di coppia - Torque limiters - Limiteurs de couple - Kupplungen							
		1.3/8"-6		1.3/8"-21		1.3/4"-6		1.3/4"-20							Bullone trancio Shear bolt clutch Limiteur à boulon Scherbolzenkupplung	Frizione a dischi Friction clutch Friction à disques Reibkupplung	Limitatore a nottolini Radial pin clutch Limiteur à cames Sternratsche	Limitatore automatico Cam clutch/cut out clutch Limiteur débrayable Nockenschaltkupplung	Ruota libera Overrunning clutch Roue libre Freilauf			
B08	 20840	 10810	 108C10	 10812	 108C12	 10813	 108H13	 10817	 108H17	 50830B	 50820B	 70830B 708C30B	 70820B 708C20B	 60550B	 60620B	 G0630	 G0620	 P4	 BTB08345712A	 F2B0834120C F4B0834200C	 LAF34250MDAB08	 R2B0834MD
B09	 20940	 10910	 109C10	 10912	 109C12	 10913	 109H13	 10917	 109H17	 50930B	 50920B	 70930B 709C30B	 70920B 709C20B	 60730B	 60620B	 G0630	 G0620	 P4	 BTB09346512A	 F4B0934200C	 LAF34250MDAB09	 R3B0934MD
L/T09	 020940	 010910	 0109C10	 010912	 0109C12	 010913	 0109H13	 010917	 0109H17	 50930T	 50920T	 70930T 709C30T	 70920T 709C20T	 60120B	 60220B	 G0440	 G0440	 P4	 BTT09346412A	 F4T0934200C	 LAF34290MDAT09	 R3T0934MD
B10	 21040	 11010	 110C10	 11012	 110C12	 11013	 110H13	 11017	 110H17	 51030B	 51020B	 71030B 710C30B	 71020B 710C20B	 60730B	 60720B	 G0630	 G0620	 P4	 BTB10344914A	 F4B1034200C	 LAF34290MDAB10	 R3B1034MD

Innovative solutions for power transmission

www.benzi.it

BENZI  Via Meda, 9
20065 Inzago (MI) Italy

BENZI  BENZI AMERICA INC.
975 Cobb Place Blvd. Suite 115
Kennesaw, GA 30144 USA

BENZI  BENZI FRANCE SARL
3 Rue Max Devaux 70000 Vesoul
Parc d'Activités Technologia FRANCE

Distributore Autorizzato - Authorized Dealer - Distributeur Agréé - Autorisierter Händler



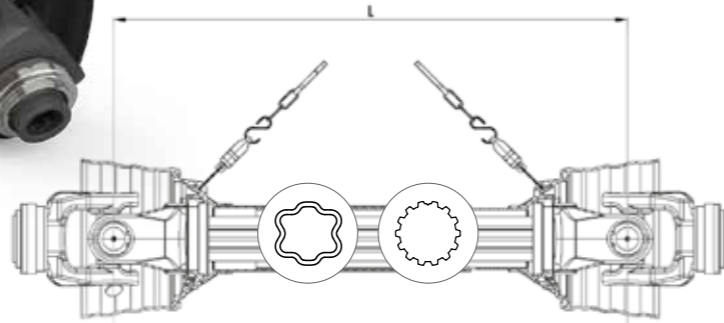

Albero tipo Shaft size Arbre type Gelenk. Typ	540 *			1.000 *		
	giri/min - rpm - U / min	giri/min - rpm - U / min	giri/min - rpm - U / min	giri/min - rpm - U / min	giri/min - rpm - U / min	giri/min - rpm - U / min
	kW	CV-HP	Mn (Nm)	kW	CV-HP	Mn (Nm)
V06	44	60	780	68	93	653
V07	66	90	1.170	102	139	980
V08	77	105	1.365	119	162	1142
V10	92	125	1.625	142	193	1.360
V12	121	165	2.145	188	255	1.795
V14	181	246	3.200	272	370	2.600

Lunghezza L (mm) - Length L (mm) Longueur L (mm) - Length L (mm)	610	660	710	760	810	860	910	1010	1110	1210	1310
Codice - Part No. Ref. - Best. Nr.	061	066	071	076	081	086	091	101	111	121	131

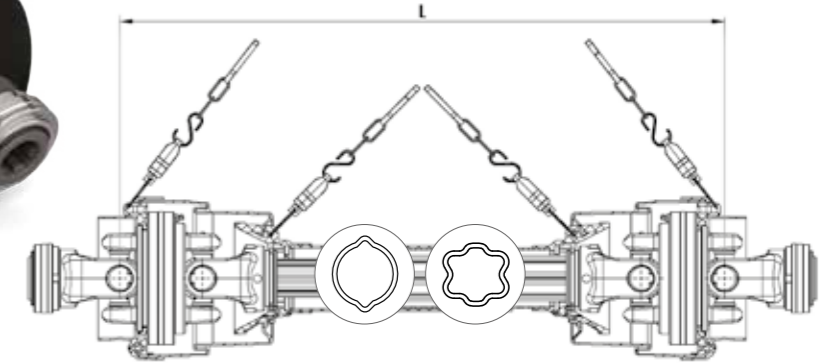









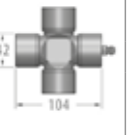

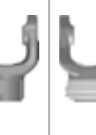











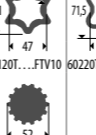







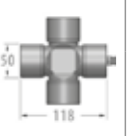









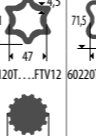







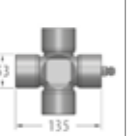







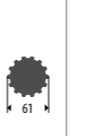







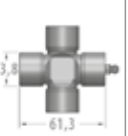
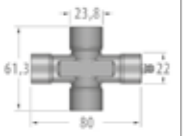





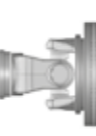

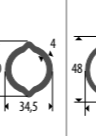
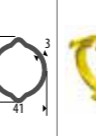





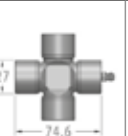
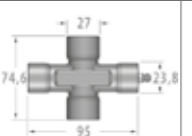







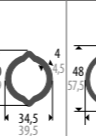







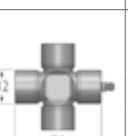
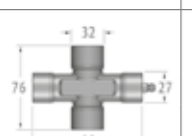











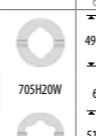
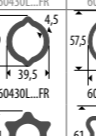







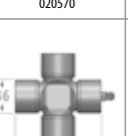
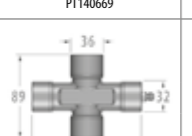











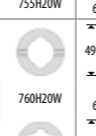
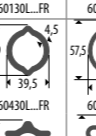



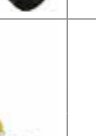



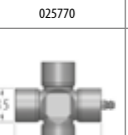
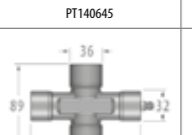

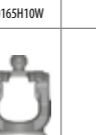
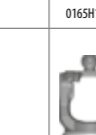









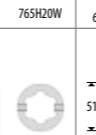
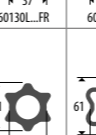





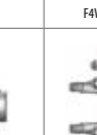

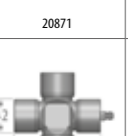
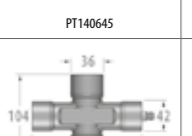



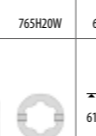
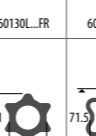

Albero tipo Shaft size Arbre type Gelenk. Typ	540 *			1.000 *		
	giri/min - rpm - U / min	giri/min - rpm - U / min	giri/min - rpm - U / min	giri/min - rpm - U / min	giri/min - rpm - U / min	giri/min - rpm - U / min
	kW	CV-HP	Mn (Nm)	kW	CV-HP	Mn (Nm)
CV2	20	27	355	31	42	295
CV4	28	38	500	44	60	415
CV6	44	60	780	68	93	653
CV7	66	90	1.175	102	139	975
CV8	77	105	1.361	113	154	1.079
CVH	92	125	1.625	142	193	1.360

Lunghezza L (mm) - Length L (mm) Longueur L (mm) - Length L (mm)	710	760	810	860	910	1010	1110	1210	1310
Codice - Part No. Ref. - Best. Nr.	071	076	081	086	091	101	111	121	131

Made in Italy

Albero tipo Shaft size Arbre type Gelenk. Typ	Crociere U. joints Croisillons Kreuzgarnituren		Forcella d'attacco End yokes Machoire d'extrémité Anschlussgabeln				Forcelle int. / est. Inner / outer yokes Machoire int. / ext. Inn. / auss. gabeln		Giunti int. / est. Inner / outer Joints Joints int. / est. Inn. / auss. gelenke		Profili telescopici Telescopic profiles Profils coulissants Profilrohre		Ghiere Retainers Bagues Gleitring		Protezioni Shields Protecteurs Schutze		Limitatore di coppia - Torque limiters - Limiteurs de couple - Kupplungen									
	Standard Side	CV Side	1.3/8"-6		1.3/8"-21		1.3/4"-6		1.3/4"-20								Bullone trancio Shear bolt clutch Limiteur à boulon Scherbolzenkupplung	Frizione a dischi Friction clutch Friction à disques Reibkupplung	Limitatore a nottolini Radial pin clutch Limiteur à cames Sternratsche	Limitatore automatico Cam clutch/cut out clutch Limiteur débrayable Nockenschaltkupplung	Ruota libera Overrunning clutch Roue libre Freilauf					
V06																										
	020571		010510	0105H10	010512	0105H12	010513	0105H13	010517	0105H17	50530T	50520T	705H30T		705H20T		60130T...F	60120T...F	GV340	GV340	V3	BTL05385610A	F2L0538120B F4L0538145B	NSL0538150	LAF38160MDAL05	R2L0538RD
V07																										
	026771		016710	0167H10	016712	0167H12	016713	0167H13	016717	0167H17	56730T	56720T	767H30T		767H20T		60130T...FT	60120T...F	GV340	GV340	V3	BTL67385610A	F2L6738120C F4L6738170C	NSL6738150	LAF38200MDAL67	R2L6738RD
V08																										
	20871		10810	108H10	10812	108SH12	10813	108H13	10817	108H17	51830T	51820T	718H30L		718H20L		60130T...FT	60120T...F	GV640	GV640	V4	BTB08345712A	F2B0834100C F4B0834200C		LAF34250MDA808	R2B0834MD

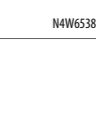
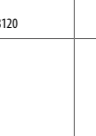
Albero tipo Shafts size Arbre type Gelenk. Typ	Crociere U. joints Croisillons Kreuzgarnituren		Forcella d'attacco End yokes Machoire d'extrémité Anschlussgabeln				Forcelle int. / est. Inner / outer yokes Machoire int. / ext. Inn. / auss. gabeln		Giunti int. / est. Inner / outer Joints Joints int. / est. Inn. / auss. gelenke		Profili telescopici Telescopic profiles Profils coulissants Profirohre		Ghiere Retainers Bagues Gleitring		Protezioni Shields Protecteurs Schutze		Limitatore di coppia - Torque limiters - Limiteurs de couple - Kupplungen							
	Standard Side	CV Side	1.3/8"-6		1.3/8"-21		1.3/4"-6		1.3/4"-20									Bullone trancio Shear bolt clutch Limiteur à boulon Scherbolzenkupplung	Frizione a dischi Friction clutch Friction à disques Reibkupplung	Limitatore a nottolini Radial pin clutch Limiteur à cames Sternratsche	Limitatore automatico Cam clutch/cut out clutch Limiteur débrayable Nockenschaltkupplung	Ruota libera Overrunning clutch Roue libre Freilauf		
V10	 020971		 010910	 010910	 010912	 010912	 010913	 010913	 010917	 010917	 51030PV	 51020V	 51020V	 710H30V	 710H20V	 60630V...FTV10	 60220T...FTIV10	 GV440	 GV440	 V5	 BT09346412A	 F4T0934200C	 LAF34290MDAT09	 R3T0934MD
V12	 021270				 011233	 0112H13	 011237	 0112H17			 51230PV	 51220V	 51220V	 712H30V013	 712H20V013	 60630V...FTV12	 60220T...FTIV12	 GV440	 GV440	 V5	 BTV12346014A		 LAF34290MDAV12	 R3V1234MD
V14	 PT146649						 011437				 51430V	 51420V	 51420V	 71430V037	 71420V037	 60630V...FTV12		 GV440	 GV440	 V5	 BTV14206014A		 LAF20400MDAV14	 R3V1420MD
CV2	 020270	 PT140704	 0123H10W	 0123H12W						 52330W	 52320W	 52320W	 723H30W	 723H20W	 60230L...FR	 60220L...	 GV240	 GV240	 V2			 N2W2338060	 R2W2338RD	
CV4	 020470	 PT140694	 0104H10W	 0104H12W						 50430W	 50420W	 50420W	 704H30W	 704H20W	 60230L...FR	 60220L...	 GV240	 GV240	 V2	 BTW40385608A	 F2W4038090B	 N2W4038060	 LAF38160MDAW40	 R2W4038RD
CV6	 020570	 PT140669	 0105H10W	 0105H12W	 0105H13W	 0105H17W	 50530W	 50520W	 50520W	 50520W	 50520W	 50520W	 705H30W	 705H20W	 60430L...FR	 60320L...	 GV340	 GV340	 V3	 BTW50385610A	 F4W5038180C	 N4W5038120	 LAF38200MDAW50	 R2W5038RD
CV7	 025770	 PT140645	 0165H10W	 0165H12W	 0165H13W	 0165H17W	 56030W	 56020W	 56020W	 56020W	 56530W	 56520W	 760H30W	 760H20W	 60430L...FR	 60320L...	 GV340	 GV340	 V3	 BTW65385610A	 F4W6538170C	 N4W6538120	 LAF38250MDAW65	 R2W6538RD
CV8	 20871	 PT140645	 0165H10W	 0165H12W	 0165H13W	 0165H17W	 56530W	 56520W	 56520W	 56520W	 56520W	 56520W	 765H30W	 765H20W	 60130L...FR	 60120L...	 GV340	 GV340	 V3	 BTW65385610A	 F4W6538170C	 N4W6538120	 LAF38250MDAW65	 R2W6538RD
CVH	 020971	 PT140645					 51030PV	 51020V	 51020V	 51020V	 51020V	 51020V	 710H30V	 710H20V	 60630V...FTV10	 60220T...FTIV10	 GV440	 GV440	 V5	 BT09346412A	 F4T0934200C	 LAF34290MDAT09	 R3T0934MD	

Leggere il libretto d'istruzioni prima dell'utilizzo di ogni trasmissione cardanica.
 Read the instructions booklet carefully prior to use.
 Lire le manuel d'instructions avant d'utiliser chaque transmission à cardan.
 Vor verwendung bitte die Gebrauchsanweisung.



ATTENZIONE
 WARNING
 ATTENTION
 ACHTUNG

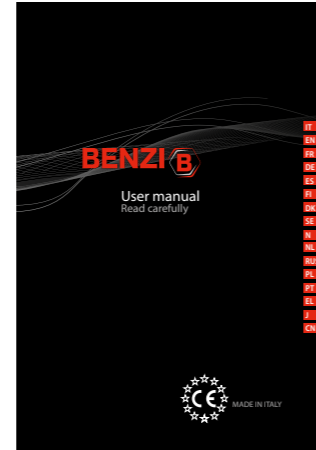
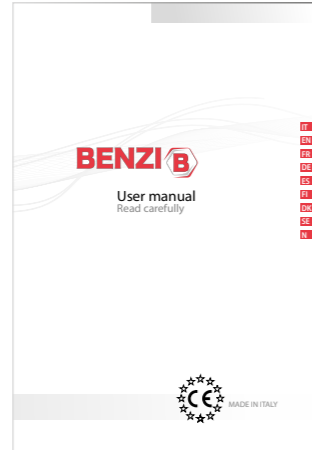

Installazione delle trasmissioni
 Drive shaft installation
 Installation des transmissions
 Installierung der Übertragungen

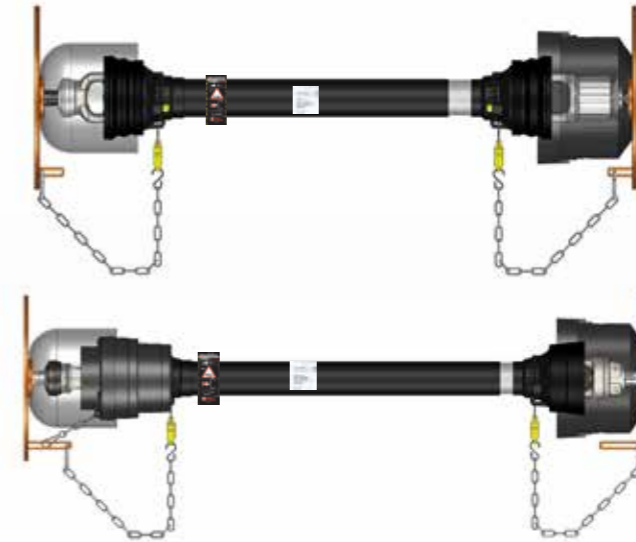

Innovative solutions for power transmission

BENZI B Via Meda, 9
 20065 Inzago (MI) Italy

BENZI B BENZI AMERICA INC.
 975 Cobb Place Blvd, Suite 115
 Kennesaw, GA 30144 USA

BENZI B BENZI FRANCE SARL
 3 Rue Max Devaux 70000 Vesoul
 Parc d'Activités Technologica FRANCE

www.benzi.it

Distributore Autorizzato - Authorized Dealer - Distributeur Agréé - Autorisierter Händler



Lubrificazione
 Lubrication
 Lubrification
 Schmierung

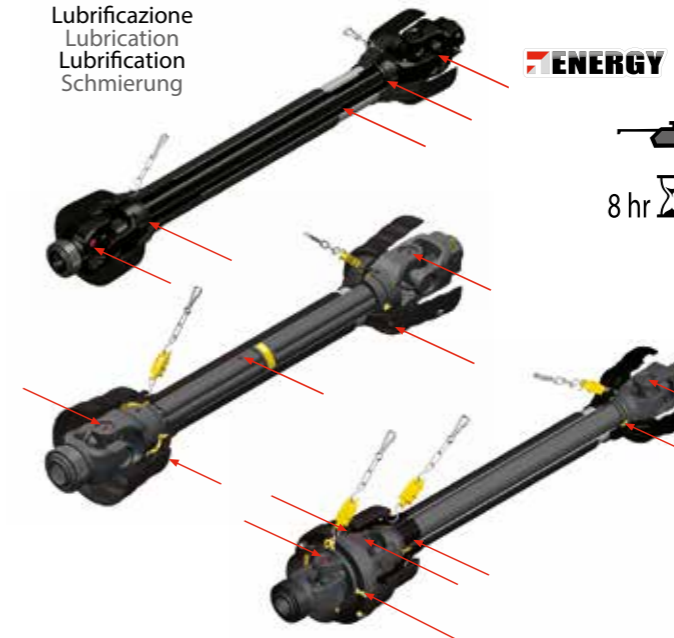

ENERGY

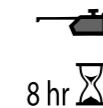

**Smart Lube
 Technology**



BENZI

PARTNER DES FACHHANDELS UND



DER WERKSTÄTTEN SEIT 1904

IDENTIFIKATIONSHILFEN & SERVICES

BENZI 

 **ENERGY**

 **evolution**
HIGH PERFORMANCE SERIES

Schaffelhuber
Großhandel · Ersatzteile & Zubehör für Landmaschinen und Industriebedarf seit 1904

